

# Meggitt Fuelling Products

## Avery-Hardoll Whittaker Controls

### SPRING SET DEMAND CONTROL VALVES F375, F377 AND F378



### F375 (three-inch), F377 (four-inch) and F378 (six-inch) spring set demand control valves

These demand regulators are basically the same units as the Whittaker air set valves except they utilize an adjustable spring to achieve control pressure. These controls can be used on vehicle applications where air pressure is not available. The addition of a solenoid valve (modification J, K or L [F375 only]) will add electrical deadman control to the valve. The valves can also be equipped with an additional air pilot valve, removing any requirement to have regulated air or air pressure gauges. The air reference port must be left open to the atmosphere but should be protected from contamination. Lockwire caps can also be provided to prevent tampering with adjustments.

Modifications H, J, K, S, V, W, and Y of the F375 upgrade the unit to a three-inch Whittaker eliminator valve. Modifications J, K, L, S, V, W, and Y of the F377 upgrade the unit to a four-inch Whittaker eliminator valve. The modifications referenced above also eliminate air-to-fuel interface.

#### Features

- Valves can be pilot air operated
- No air to fuel interface
- No set air pressure regulation required on some modifications - see option list
- Eliminates the need to have air regulators or gages
- Ask about our eliminator valve version of the F377 or F375
- Surge control adjustment on valve
- Pressure control adjustment on valve
- Adjustments factory set
- Adjustment cap can be provided with lockwire type cap screws

See the modification section of this catalog for various options to the part number listed above.

Contact your local Whittaker distributor or Whittaker directly for technical information beyond that listed in the technical section of this catalog.

#### Operating characteristics

- Working pressure - 200 PSI
- Closure times:
  - dead man release - 0.8 sec [4.0-5.0 sec on modifications H, J, or K (F375 only)]
- Aircraft valve response - 0.75 sec
- Adjustable feature [optional with modification "AH" (F378) or "AN" (F377) only]
- Opening times - 10 to 50 seconds (set at 23 sec)
- Pressure control range - 30 to 60 PSI (70 to 110 PSI on "X" modification)
- Peak surge pressure - 275 PSI

#### SPECIAL NOTES:

For proper operation:

Fuel line from the required remote sensing point must be .375 inch I.D. minimum.

Inlet piping must be straight for 15-inches and of same I.D. as valve.

# MEGGITT

# SPRING SET DEMAND CONTROL VALVES

## F375, F377 AND F378

F375 (three-inch) dimensions

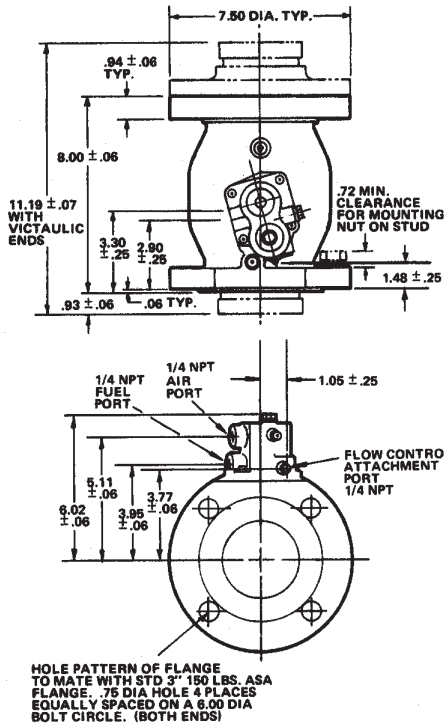

F377 (four-inch) dimensions

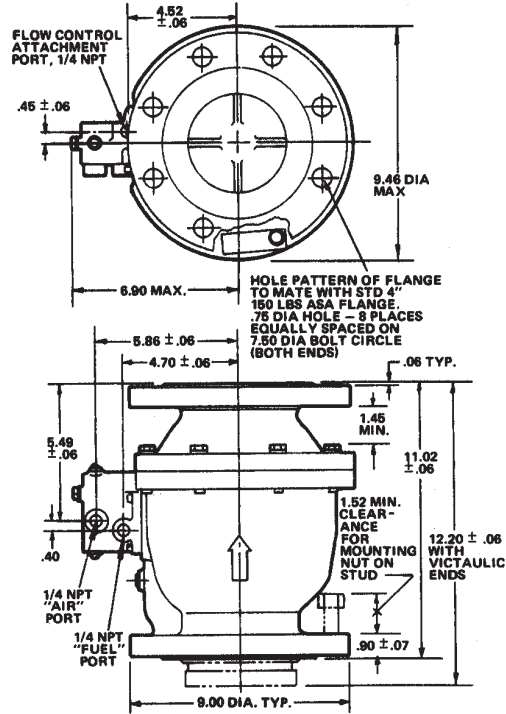

F378 (six-inch) dimensions

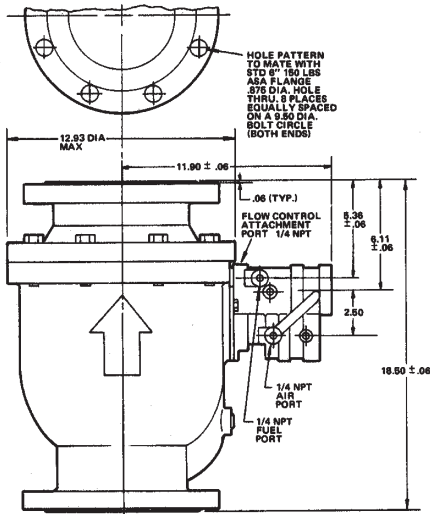

Functional schematic

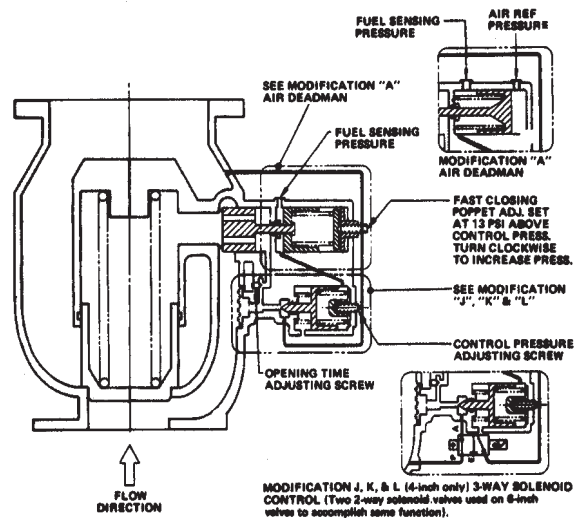

Avery-Hardoll  
Holland Way  
Blandford Forum  
Dorset DT11 7BJ  
UK

Tel: +44 (0) 1258 486600  
Fax: +44 (0) 1258 486601

www.meggittfuelling.com

Whittaker Controls  
12838 Saticoy St  
North Hollywood  
California 91605-3505  
USA

Telephone: +1 818 765 8160  
FAX: + 1818 759 2194

www.wkr.com  
www.meggitt.com

Aljac Fuelling Components Ltd  
Unit 2, 14 Brooklands Close  
Sunbury on Thames  
Middlesex TW16 7DX  
UK

Tel: +44 (0) 1932 779588  
Fax: +44 (0) 1932 779599

www.aljac.com

