

INSTALLATION INSTRUCTIONS

Upgrade of

Meggitt/Avery Hardoll Hydrant Valves

PVMY1000M1 or PVMY1000M2

To

PVMY1000M3 Standard

June 2009.

INSTALLATION INSTRUCTIONS

FOR

Upgrade of

Meggitt/Avery Hardoll Hydrant Valves

P/N PVMY1000M1 or PVMY1000M2

To

PVMY1000M3 Standard

Prepared By: 
J. Wong, Director of Engineering, Fueling Products

Reviewed By: 
Jerry Pham, Engineering Specialist

Approved By: 
J. Wong, Director of Engineering, Fueling Products

Approved By: 
Lucia Coates, Quality Engineer

NOTICE: THIS DOCUMENT IS PART OF THE PROPRIETARY ARTICLE, HEREIN DISCLOSED, OWNED BY WHITTAKER CONTROLS, A DIVISION OF MEGGITT PLC. THE UNITED STATES, (OR OTHER PARTY TO WHOM FURNISHED OR HAVING POSSESSION HEREOF), BY ACCEPTING THIS DOCUMENT, ASSUMES CUSTODY AND CONTROL HEREOF AND AGREES: (A) THE INFORMATION SET FORTH HEREIN IS GIVEN IN CONFIDENCE, AND THIS DOCUMENT WILL NOT BE COPIED OR REPRODUCED, IN WHOLE OR IN PART, NOR ITS CONTENTS REVEALED IN ANY MANNER TO ANY PERSON EXCEPT TO MEET THE PURPOSE FOR WHICH IT WAS DELIVERED. (B) WITHOUT THE WRITTEN CONSENT OF WHITTAKER CONTROLS, INC., A DIVISION OF MEGGITT PLC, THIS DOCUMENT IN WHOLE OR IN PART, AND THE INFORMATION CONTAINED HEREIN UNDER NO CIRCUMSTANCES WILL BE USED IN THE MANUFACTURE OR PRODUCTION OF THE ARTICLE SHOWN, AND DELIVERY OF THIS DOCUMENT SHALL NOT CONSTITUTE ANY RIGHT OR LICENSE TO DO SO.
*THIS LEGEND SHALL BE MARKED ON ANY REPRODUCTION HEREOF IN WHOLE OR IN PART.

REVISION PAGE

REV LTR	PAGES AFFECTED	DESCRIPTION OF CHANGE	DATE	APPROVED BY
N/C	ALL	INITIAL RELEASE		
A	6	430090 WAS 2681242-2	2009-3-30	JW
B	3 5	Para. 2.1.3: ...2,2,6 was 2.2.7 Para. 2.1.4: PVSZ152 was Z022E263139A Fig 1: PVSZ152 was PVSC152	2009-6-5	JW
C	3& 4	REVISED PARA. 2.1.2 AND 2.2.7	2009-6-10	JW

1.0 **OBJECTIVES**

This Installation Manual #7068 is to provide detail instruction for field upgrade of Meggitt/Avery Hardoll hydrant valves P/N PVMY1000M1 or PVMY1000M2 to the PVMY1000M3 standard in compliance to the API/EI 1584, 3rd Edition requirements.

2.0 **UPGRADE PROCEDURE**

Figure 1 and 2 are applicable to both Meggitt/Avery Hardoll hydrant valves P/N PVMY1000M1 or PVMY1000M2.

Figure 1 depicts all old components that are to be removed from the PVMY1000M1 or PVMY1000M2 hydrant valve to start the upgrade process. Paragraph 2.1 details the disassembly procedure.

Figure 2 depicts all new components to be installed onto the existing lower hydrant valve half to facilitate upgrade to the PVMY1000M3 standard. Paragraph 2.2 details the re-assembly procedure.

2.1 **DISASSEMBLY PROCEDURE**

The upgrade to the Meggitt/Avery Hardoll hydrant valves P/N PVMY1000M1 or PVMY1000M2 can be performed with the valve installed in the hydrant pit. No hydrant valve removal from the hydrant pit is necessary.

- 2.1.1 For a pneumatic operated hydrant valve, check to make sure the pilot valve is vented of all trapped pressurized air. For manually operated hydrant valve, ensure the manual pilot is placed in closed position.
- 2.1.2 Place the isolation valve in the hydrant valve lower half in opened position and insert the locking clip P/N PVSZ132 under the pilot push button.
- 2.1.3 Unscrew the 8 socket head cap screws P/N ZS4025M12025A.

Note that unscrewing of these 8 screws will release the upper half adapter of the hydrant valve from the lower half. These two valve halves are under spring load at assembled condition. Use caution while the last screw is untorqued.

Also, separation of the hydrant valve upper and lower halves will allow release of trapped fuel in the valve. Spillage of less than 1 liter of fuel is expected.

Remove but do not discard these 8 screws, they will be reused in the assembly process per paragraph 2.2.6.

- 2.1.4 Remove upper half API Adapter P/N PVSZ152.

2.1.5 Remove the upper half poppet valve assembly as a whole.

The upper half poppet valve assembly includes the following parts

P/N	CCRZ7168	Valve Seal	qty. 1
	ZS4025D0608L	Screw	6
	PVSZ314	Valve Stem	1
	Z032E111103A	O-ring	1
	CCSZ7206	Pip Valve	1
	RVSZ3451	Compression Spring	1
	ZS4016D0408L	Screw	3
	CCAZ7148	Valve Head	1
	CCAZ7185	Seal Retaining Plate	1

2.1.6 Remove the Compression Spring P/N CCSZ528.

2.1.7 Remove and discard O-ring P/N Z022E263139A.

2.2 RE-ASSEMBLY PROCEDURE

Use Meggitt upgrade kit P/N 80318 to facilitate upgrade of the hydrant valve to Meggitt P/N PVMY1000M3 standard. All components included in this upgrade kit are shown in Figure 3 of this manual.

2.2.1 Install the new O-ring P/N Z022E263139A from the upgrade kit to the seal gland in the lower half of the hydrant valve.

2.2.2 Assemble the Inner Chamber P/N 430082 onto the pip valve guide of the lower half.

2.2.3 Place the Poppet Spring P/N 2681220 into the Inner Chamber.

2.2.4 Place the Poppet Assembly P/N 430090 onto the Poppet Spring.

2.2.5 Place the API Adapter P/N 231477 over the Poppet Assembly. Compress the Poppet Spring until the API Adapter engages the hydrant valve lower half.

2.2.6 Use the 8 socket head cap screws P/N ZS4025M12025 to secure the API Adapter against the hydrant valve lower half. Torque the socket head screws at 400 in-lbs.

2.2.7 Remove the Locking Clip P/N PVSZ132 from the pilot bush button.

Upgrade of the Meggitt/Avery Hardoll hydrant valves P/N PVMY1000M1 or PVMY1000M2 to the PVMY1000M3 standard in compliance to the API/EI 1584, 3rd Edition is complete.

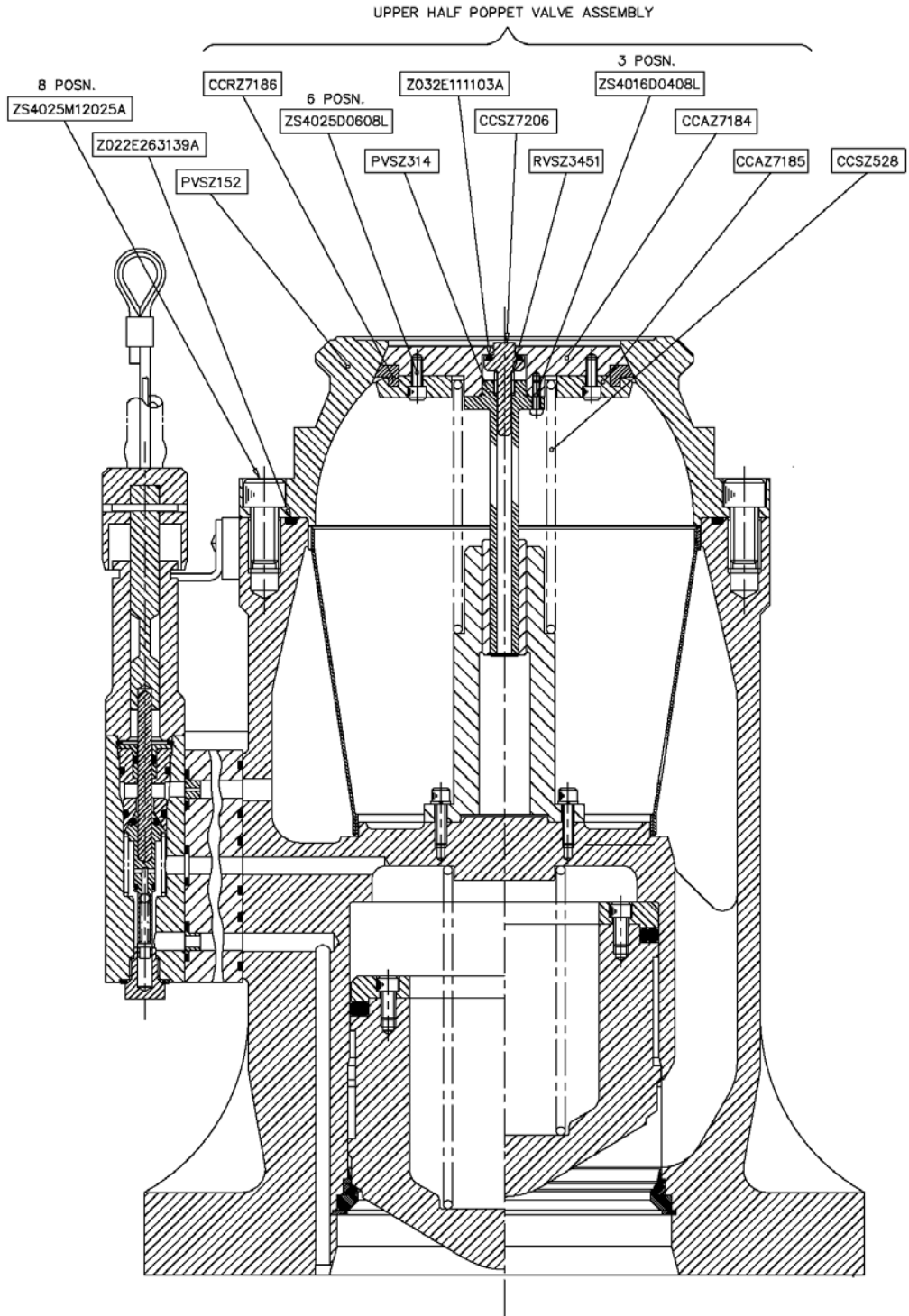

Figure 1: Parts to be replaced from PVMY1000M1 or PVMY1000M2

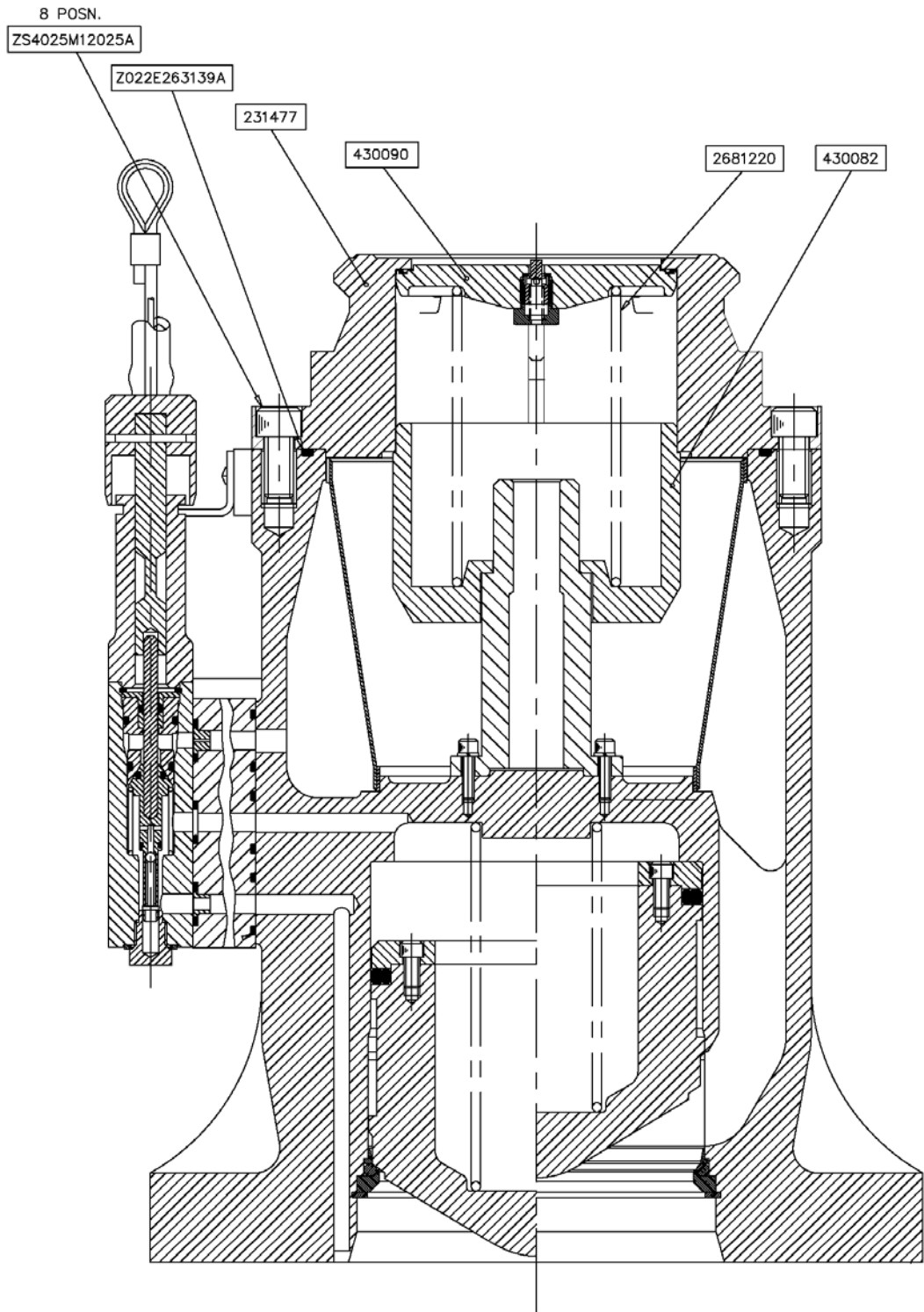

Figure 2: Parts added to upgrade PVMY1000M1 or PVMY1000M2 to PVMY1000M3 standard



Figure 3: Upgrade Kit P/N 80318 for PVMY1000M1 and PVMY1000M2 to PVMY1000M3 standard