

Eaton's Carter product line includes several hydrant pit valve models. Model 61524 2½-inch Hydrant Valve is designed to provide deadman control of the refueling operation within the hydrant pit. Both air and lanyard operation is available. This model is available with either 6 or 4-inch inlet flanges and both terminate with the 2½-inch international standard three-lug aircraft bayonet adapter. Now also available with an adapter kit to install the unit in older 12 and 13-inch diameter pits with 3-inch mounting flanges. Model 61524 utilizes many of the same parts as are used in Eaton's other hydrant valve models. The basic valve assembly consists of three parts, lower valve assembly, upper valve assembly and the pilot valve. The lower valve assembly contains a small isolation valve which will allow removal and servicing of the upper valve assembly and the pilot valve while the pit

valve is under pressure (see maintenance manual SM61524 for proper instructions for use).

Model 61524 is designed to minimize the propagation of surge pressure shocks into the upstream piping system during closure of the valve.

## Features

- Closing time: 2-5 sec  
Opening time: 5-10 sec
- Either lanyard or air operated pilot valve available
- Standard inlet flange mates with 4-inch 150 lb ANSI flange standard (optional 6-inch 300 lb inlet available)
- Large pressure equalizing valve in the outlet is standard
- Defueling capability optional with air operated pilot valve
- Main piston well-guided to minimize piston seal wear
- Ductile iron is epoxy coated for corrosion protection
- Minimum of bonded seals utilized to reduce maintenance costs

## Technical Information

- Working pressure: 300 psi (20.68 bar)
- Closing time: 2 to 5 sec
- Opening time: 5 to 10 sec (from zero to 600 USgpm [2271 l/min])
- Overshoot: 30.0 gals maximum at 600 gpm (2271 l/min)
- Pilot valve air pressure required for options E or J — 60 psi min (4.136 bar)
- Materials:  
Outer housings — A536, grade 60-40-18 ductile iron  
Bayonet adapter (outlet) — aluminum bronze  
Trim— stainless steel and aluminum alloy

## Mating Parts

Model 61524 Hydrant Valve will mate Eaton's Carter Model 61445 Hydrant Couplers, older Model 60445 couplers (superseded by Model 61445), or any other standard 2½-inch coupler, regardless of brand.

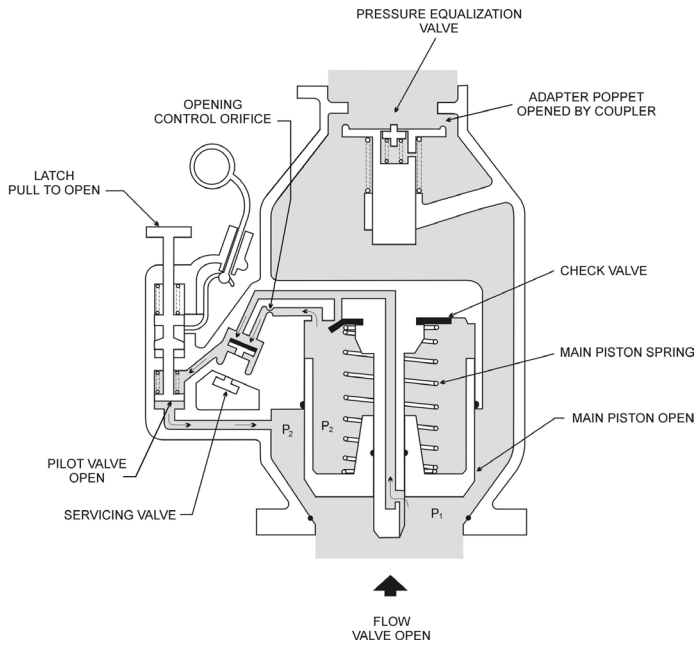

**Figure A**

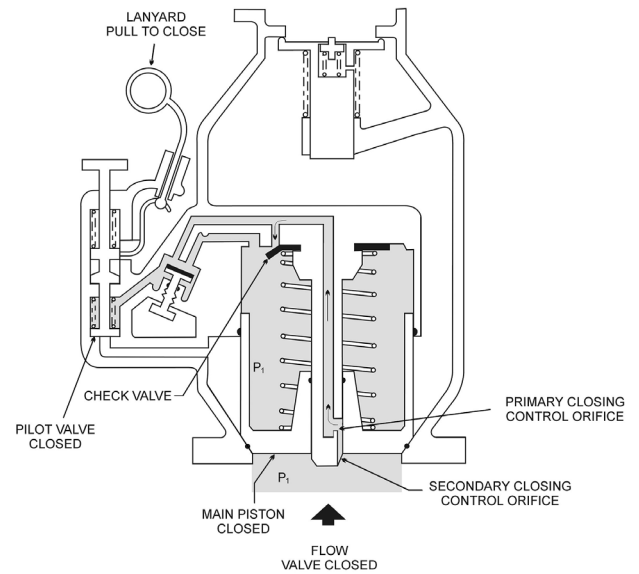

**Figure B**

Figure A reflects a lanyard operated pilot valve shown in the open position. The operation of the hydrant valve, whether the pilot is lanyard or air operated, is identical. Figure B reflects the same hydrant valve with the air pilot in a closed position. The only differences between the two units are in the operating mechanism that supplies the power to open and close the pilot valve. In the air operated pilot, the closing lanyard and opening latching mechanisms are replaced with an air operated piston.

### Servicing Valve Closed/ Pilot Valve Open or Closed

The closing of the servicing valve has the same affect as closing the pilot valve. That is, the flow passage from the piston chamber to the downstream side of the piston is blocked. The piston chamber pressure begins to equalize to the inlet pressure (P1) through the check valve. The piston area is greater than the effective seal area, hence the unbalance of forces caused by the equal pressure, plus the spring, will cause the valve to stay closed.

### Pilot Valve Open/ Servicing Valve Open

The open pilot valve allows the continuous passageway from the main piston chamber and from the closing control orifice. The piston chamber is vented through an opening control orifice and the open servicing valve to a point in the lower valve half. The pressure (P2) at this point is less than the inlet pressure (P1). The piston chamber pressure is also maintained at P2 causing an unbalance of forces on the piston. The inlet pressure force is greater than the combined piston pressure force plus the spring force hence the valve will open to allow flow. This is assuming that the outlet adapter poppet in the upper valve half has been opened by a coupler.

The pilot poppet is maintained in the open position by one of two methods:

- Lanyard operated pilot: The pilot is opened by the pull of the "T" handle located on the top of the pilot valve. When it is pulled

upward, the spring loaded latch attached to the lanyard pivots to lock the pilot into the open position.

- Air operated pilot: Air pressure applied to the pilot piston will maintain the pilot in the open position until the pressure has been depleted (by release of deadman)

### Pilot Valve Closed/ Servicing Valve Open

Pulling the lanyard, or depleting the air supplied to their respective pilots, will allow the spring loaded pilot poppet to close. This action blocks off the venting of the piston chamber to the lower pressure area downstream. The piston chamber begins to equalize to the inlet pressure (P1) through the check valve. The piston area is greater than the effective seal area, hence the unbalance of forces caused by the equal pressure plus the spring will cause the piston to begin to close. As the piston moves toward the closed position, the piston chamber volume increases and must be filled through the two series orifices.

The primary orifice is considerably larger than the secondary (slot). During the initial and majority of the travel of the piston, the primary orifice is fully exposed to the inlet pressure, hence the rate of closure is controlled by this orifice. When the piston moves far enough closed to cover the primary orifice, the secondary (smaller) orifice begins to control the closure rate. Hence the valve begins to close relatively rapidly and then slows down as it nears its closed position. The relative size and locations of these two orifices allows the valve to close to provide a minimum of overshoot and yet limit the surge pressure shock, on closing, and still maintain a closure rate in accordance with applicable international specifications.

On defueling option J, the pilot valve is manually held closed by the thumb screw to allow defueling flow.

## Flow Characteristics

The chart (right) depicts typical pressure drop versus flow characteristics of Eaton's Carter Model 61524 Hydrant Pit Valves with a mating Model 60445 or 61445 Coupler.

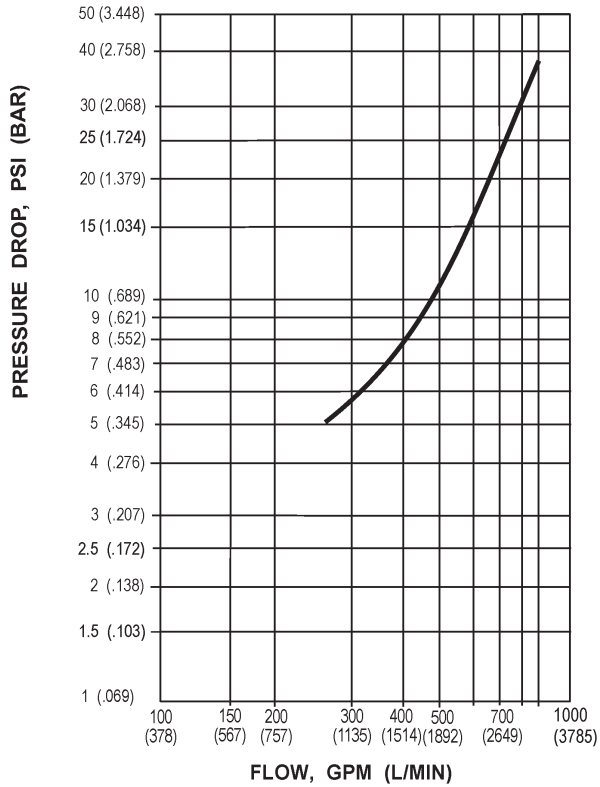

## Installation Data

It is critical that the mating coupler be connected correctly and the pit lid be able to close completely. The hydrant valve's installation depth depends upon the brand of pit used. The thickness of the pit lid should be checked to be sure that it will clear the hydrant valve before setting the pit. The dimensions noted herein were correct for pits made in the United States at the time of printing. Eaton cannot be responsible for changes in the pits. The dimensions shown are for reference only.

Dimensions shown in inches (millimeters).

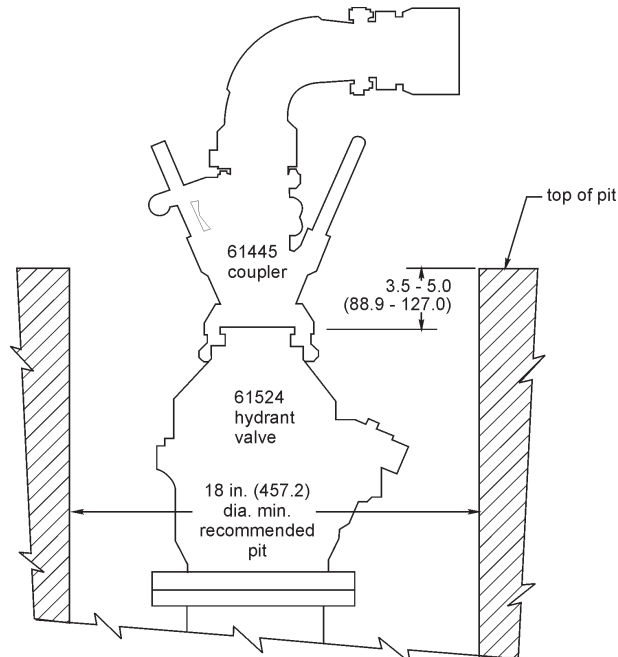

There are three basic valve model numbers to which various modifications may be made by adding option letters as shown in the table (right).

**Model 61524D**

Lanyard operated pilot valve for manual on/off control.

Valve allow flow in the fueling direction only.

Weight — 49.0 lbs (22.226 kg)

**Model 61524E**

Air operated pilot valve for the deadman control. Valve allows flow in the fueling direction only.

Weight — 49.0 lbs (22.226 kg)

**Model 61524J**

Air operated pilot valve for the deadman control with defuel control to allow flow on fuel in either the fueling or defueling direction.

Weight — 50.0 lbs (22.680 kg)

Option Letter	Description
A	Adds strainer, 10-mesh
B	Adds strainer, 20-mesh
C	Adds U.S. standard product selection for positions 4, 5, and 6
D	Adds manually operated pilot valve
E	Adds air operated pilot valve
F	Adds dual air operated pilot valve
G	Adds 6 to 4-inch IP adapter
H	Adds 4-mesh stoneguard to Option G only
J	Adds air operated defuel pilot valve
M	Adds QD to air pilot connection on Options E and J only. Mates Hansen socket B2-H16
N	Adds hardware kit to allow installation into 12 or 13-inch pits with 3-inch ANSI mounting flanges

**Example:**

61524CEGHM — Air-operated hydrant valve with 6- to 4-inch IP adapter, stoneguard, product selection and QD on the air port

**Envelope Dimensions**

The drawing (right) provides envelope dimensions for installation purposes only. They are not intended for inspection purposes.

Dimensions shown in inches (millimeters).

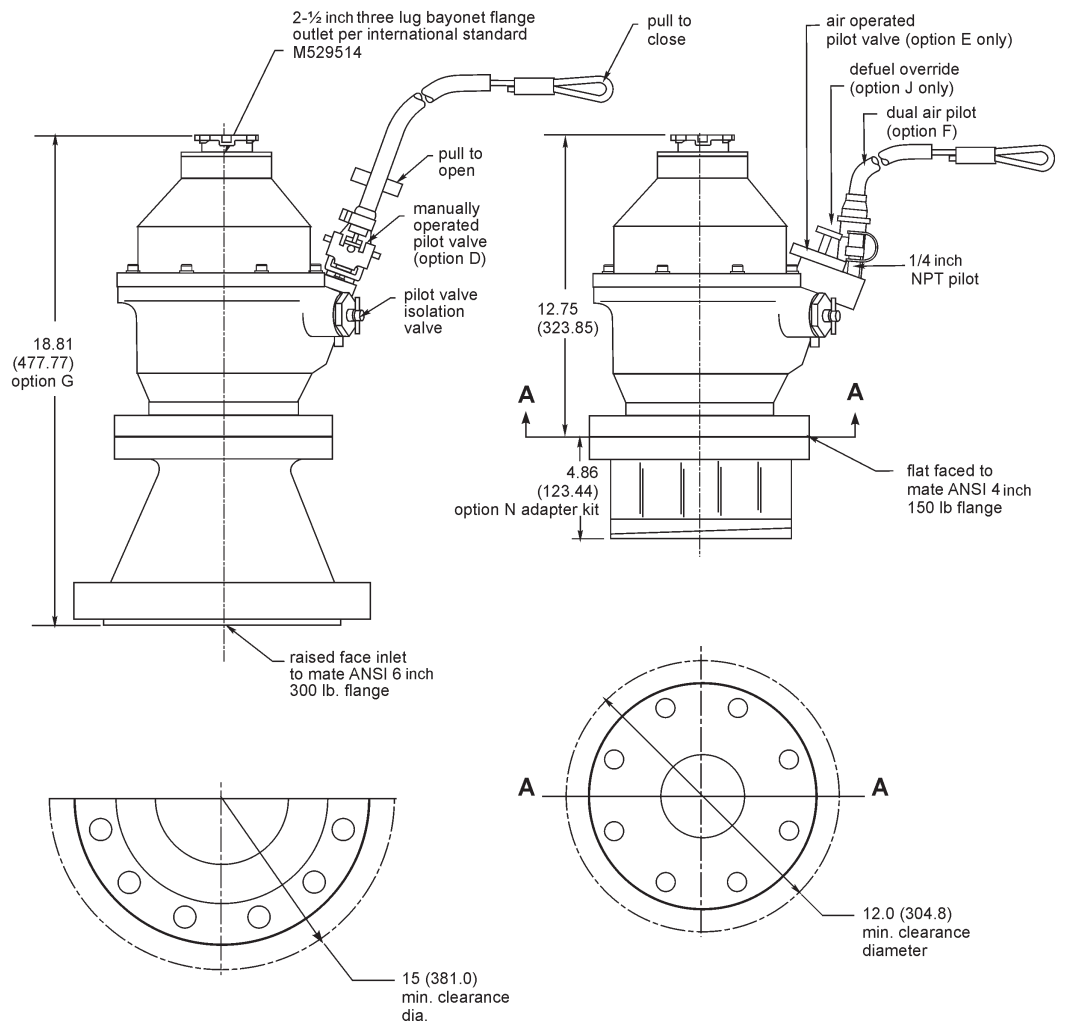

**Eaton**  
**Aerospace Group**  
**Fluid & Electrical Distribution Division**  
**9650 Jeronimo Road**  
**Irvine, California 92618**  
**Phone: (949) 452 9500**  
**Fax: (949) 452 9992**  
**E-mail: [groundfueling@eaton.com](mailto:groundfueling@eaton.com)**